



# ES1AL THRU ES1JL

## SURFACE MOUNT SUPER FAST RECOVERY RECTIFIERS

Reverse Voltage - 50 to 600 Volts    Forward Current - 1.0 Ampere

### SOD-123 FL

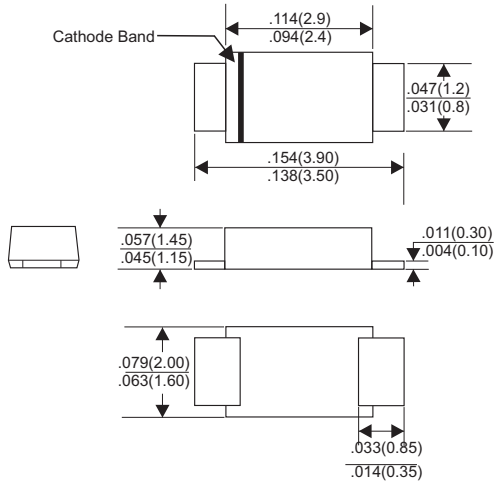

Dimensions in inches and (millimeters)

## FEATURES

- \* Glass passivate device
- \* Ideal for surface mounted applications
- \* Low reverse leakage
- \* Metallurgically bonded construction
- \* High temperature soldering guaranteed:  
250°C/10 seconds 0.375"(9.5mm)lead length,  
5 lbs.(2.3kg) tension

## MECHANICAL DATA

- \* Case: JEDEC SOD-123FL molded plastic
- \* Terminals: Plated axial leads, solderable per MIL-STD-750, Method 2026
- \* Polarity: Color band denotes cathode end
- \* Mounting Position: Any

## MAXIMUM RATINGS AND ELECTRICAL CHARACTERISTICS

Rating 25°C ambient temperature unless otherwise specified.  
Single phase half wave, 60Hz, resistive or inductive load.  
For capacitive load, derate current by 20%.

TYPE NUMBER	ES1AL	ES1BL	ES1CL	ES1DL	ES1EL	ES1GL	ES1JL	UNITS
Maximum Recurrent Peak Reverse Voltage	50	100	150	200	300	400	600	V
Maximum RMS Voltage	35	70	105	140	210	280	420	V
Maximum DC Blocking Voltage	50	100	150	200	300	400	600	V
Maximum Average Forward Rectified Current .375"(9.5mm) Lead Length at Ta=55°C	1.0							A
Peak Forward Surge Current, 8.3 ms single half sine-wave superimposed on rated load (JEDEC method)	30							A
Maximum Instantaneous Forward Voltage at 1.0A	0.95			1.3		1.7		V
Maximum DC Reverse Current Ta=25°C	5.0							µA
at Rated DC Blocking Voltage Ta=100°C	50							µA
Maximum Reverse Recovery Time (Note 1)	35							nS
Typical Junction Capacitance (Note 2)	15							pF
Operating and Storage Temperature Range T <sub>J</sub> , T <sub>STG</sub>	-65 — +150							°C
Marking code	EA	EB	EC	ED	EE	EG	EJ	

### NOTES:

1. Reverse Recovery Time test condition: IF=0.5A, IR=1.0A, IRR=0.25A
2. Measured at 1MHz and applied reverse voltage of 4.0V D.C.

# RATING AND CHARACTERISTIC CURVES (ES1AL THRU ES1JL)

FIG.1-TYPICAL FORWARD CHARACTERISTICS

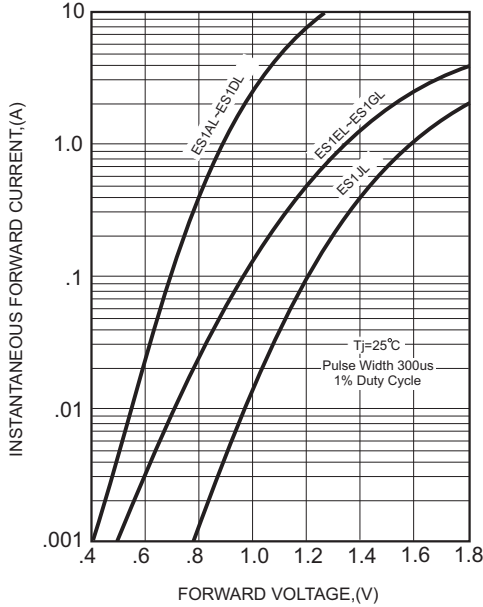

FIG.2-TYPICAL FORWARD CURRENT DERATING CURVE

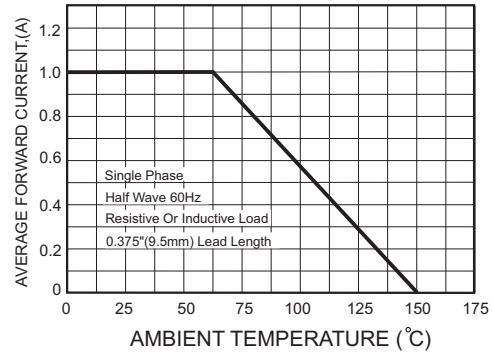

FIG.4-MAXIMUM NON-REPETITIVE FORWARD SURGE CURRENT

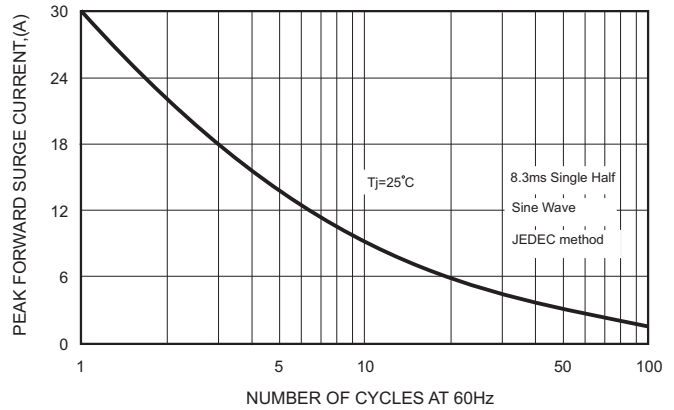
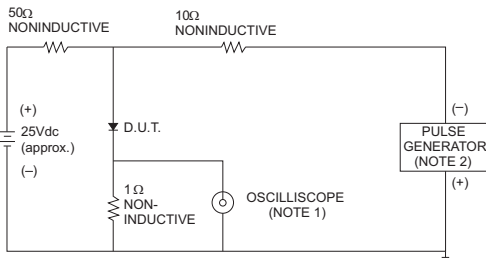

FIG.3- TEST CIRCUIT DIAGRAM AND REVERSE RECOVERY TIME CHARACTERISTICS



- NOTES: 1. Rise Time= 7ns max., Input Impedance= 1 megohm, 22pF.  
2. Rise Time= 10ns max., Source Impedance= 50 ohms.

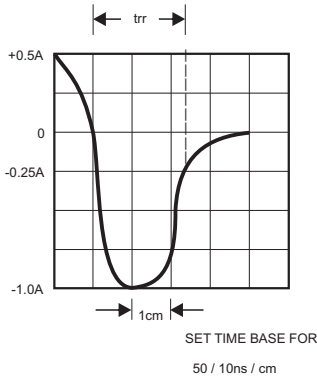

FIG.5-TYPICAL JUNCTION CAPACITANCE

